

Datasheet

Torque sensor

DRBL

Torque ranges from 0,5 Nm to 1000 Nm

NEW!



The DRBL series

- current and voltage output
- measurement accuracy $\leq 0.25\%$
- contactless signal transmission
- proven strain gauge technology
- built-in signal amplifier
- simple power supply
- universally applicable
- RPM measurement optional

The new features:

- more versatile mounting options
- torsion shaft stainless
- mistake-proof installation
- oriented mounting
- large coupling selection

The torque sensors of the DRBL series are a further development of our DRBK series and are suitable for use in the laboratory and for industrial environments with their compact dimensions and diverse mounting options.

A factory calibration certificate with 25% increments (left, right) is included in the scope of delivery.

The non-contact transmission of the measurement signal and the supply energy enables low-wear and maintenance-free continuous operation.

Technical Specifications DRBL

Supply voltage:	11,5 to 28,8 V DC
Current consumption:	approx. 200 mA
Rise time 10-90 %:	1 ms
Limit frequency –3 dB:	1 kHz
Voltage output:	0 to ± 5 V
Internal resistance:	100 Ω
Current output:	10 ± 8 mA Burden max 500 Ω
Ripple:	< 100 mVpp
Nonlinearity:	< 0,2 %
Hysteresis:	< 0,2 %
Deviation at zero point:	≤ ± 100 mV / ± 200 μA
Max. measurement error	0,25 % (FS / of full scale)
Operating temperature:	0 - 60 °C
Compensated temperature range:	5 - 45 °C
Temperature error	
Zero point:	0,05 % / K
Sensitivity:	0,02 % / K
Mechanical overload:	100 %
Internal protection:	IP40
Connection:	12pin- connector

EMV Immunity for interference (DIN EN 61326-1 / EN 61000-6) *

Enclosure	Severity	Criterion
HF line interference 150 kHz - 80 MHz (AM)	3 V	A
(ESD) Electrostatic discharge	Air 8 kV Contact 4 kV	A A
Enclosure		
Electromagnetic Field		
80 MHz - 1000 MHz (AM)	10 V/m	A
80 MHz - 2700 MHz (AM)	10 V/m	A
Leads - Connection Cable		
Burst (fast transients)	2 kV	A
Surge voltage (Surge)	1 kV	B
Interference Emission (EN 61326-1 / EN 55011)		
Disturbance Voltage (Electromagnetic Disturbances)	-	Class B (150 kHz - 30 MHz)
Radiated Emission (Electromagnetic Disruption axis)	-	Class B (30 MHz - 1000 MHz)

Speed Option (n)	
max. rev.:	up to 22 000 min ⁻¹ **
Output:	Open-Collector
Internal pull up:	4,7 kΩ (5 V level)
External pull up:	24 V max / 20 mA
Pulses/rev.:	60

* Severity / Criterion: industrial environment;
Cable length ≤ 30m.
Application not outside buildings.

** by proper external connections (depending on cable length and capacity) up to speed max.

Mechanical Dimensions DRBL

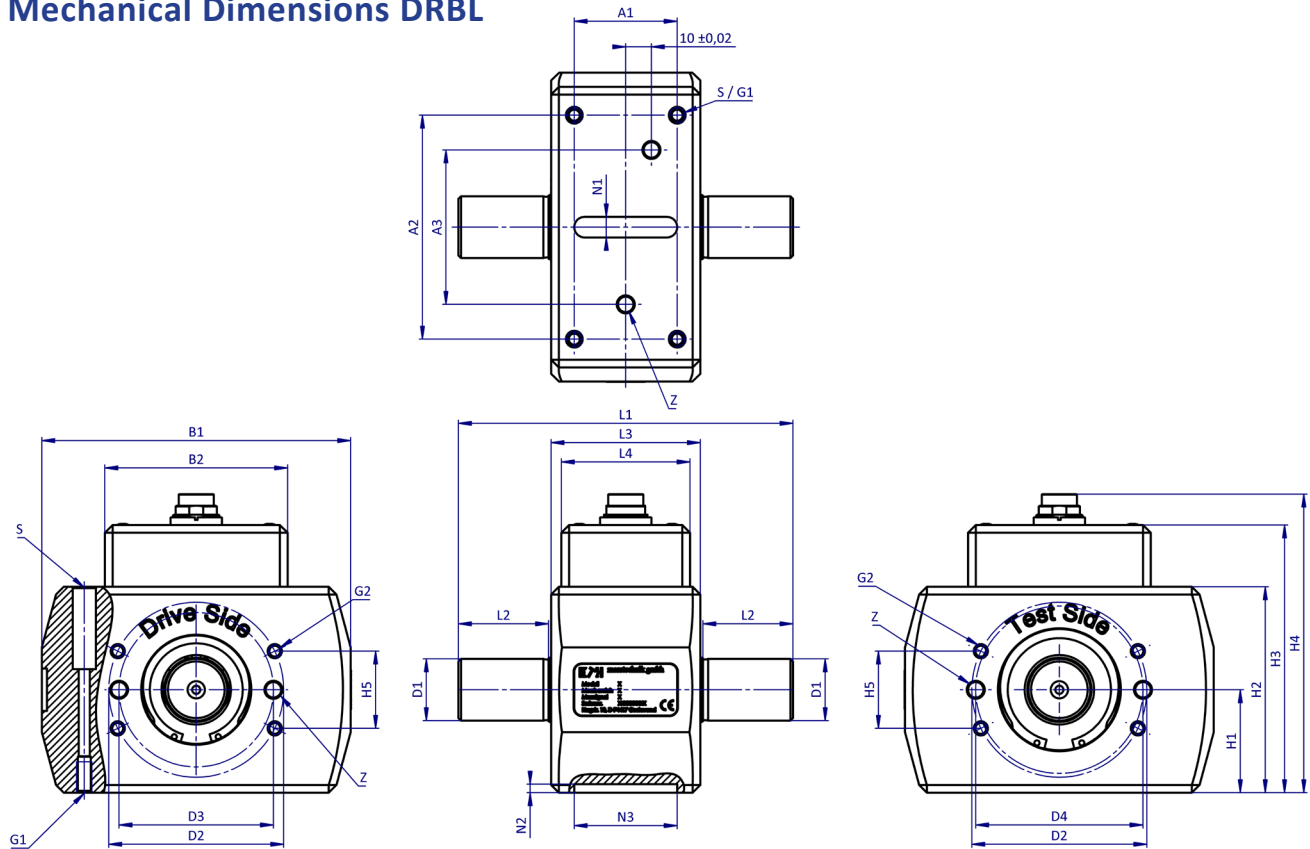

Model:	DRBL-I	DRBL-II	DRBL-III	DRBL-IV
Measuring range (0 - ...) : [Nm]	0,5 1 2	5 10 20	50 100 200	500 1000
Dimensions: [mm]	General tolerances DIN 2768-m			
L1	80	110	130	170
L2	15	27	35	50
L3	48	54	58	68
L4	43	48	58	58
B1	75	90	120	150
B2	45	48	71	86
H1 ±0,02	25	30	40	50
H2	50	60	80	100
H3	65	78	104	130
H4	77	90	116	142
H5 ±0,10	22	26	30	40
D1 g6	6	15	24	40
D2 ±0,10	35	52	68	95
D3 ±0,02	30	45	60	85
D4 ±0,02	35	50	65	90
A1 ±0,10	35	38	40	46
A2 ±0,10	54	62	87	106
A3 ±0,02	40	50	60	80
G1	M5 x 10	M6 x 12	M6 x 12	M8 x 16
G2	M4 x 8	M5 x 10	M5 x 10	M6 x 12
Z E8	Ø4 x 6	Ø5 x 7	Ø6 x 8	Ø8 x 10
S	Ø7 x 20U - Ø3,4	Ø9 x 26U - Ø4,3	Ø9 x 32U - Ø4,3	Ø11 x 30U - Ø5,5
N1 H8	6	8	8	8
N2 +0,2	2,8	3,3	3,3	3,3
N3 +0,3	30	35	40	50
Weight: [g]	≈ 230	≈ 550	≈ 850	≈ 2500

Technical Specifications DRBL

Model	Measuring range (0 - ...) [Nm]	max. RPM [min ⁻¹]	Spring Constant [Nm/rad]	Mass moment of inertia [g x cm ²]			Permitted axial load* [N]	Permitted radial load* [N]
				Total	Drive side	Measuring side		
DRBL-I	0,5	25.000	141	15,1	14,3	0,8	194	25
	1	25.000	141	15,1	14,3	0,8	194	25
	2	25.000	277	15,2	14,3	0,8	194	50
DRBL-II	5	22.000	1126	113	89	24	580	80
	10	22.000	2590	114	90	24	580	160
	20	22.000	5160	114	90	24	580	320
DRBL-III	50	16.000	18.954	444	291	153	1000	675
	100	16.000	33.237	452	295	157	1000	1350
	200	16.000	45.609	467	303	164	1000	2000
DRBL-IV	500	9500	283.554	4275	2389	1886	2450	4750
	1000	9500	408.370	4444	2473	1971	2450	4900

*The values for axial and radial load refer to the non-fixed housing

Mounting possibilities

The DRBL series offers simplified assembly and thus ensures a distinctive installation:

- Fastening on the base from above and below.
- Alignment by feather key connection and straight pins for quick installation and removal.
- Fastening at the front using threads and straight pins.
- Positioning using straight pins prevents the measurement and drive sides from being mixed up when reinstalling.
- Longer shaft ends allow for a wide selection of couplings.

Mounting material

Feather key and straight pins included.

Available Accessories

- ETH-Measurement cable (Are optimized in design and shielding.)
- Display and evaluation devices
- Couplings

Ordering code

