

Torque transducer Type DRBK with speed detection



Special features:

- Very short construction
- Broad input voltage range
- Current output and voltage output
- Measurement accuracy:
≤ 0,5% of full scale
- Measurement ranges from 5 to 1000 Nm
- Contactless transfer of measured signal
- Approved strain gauge technology
- Internal measurement amplifier
- Speed detection optional available
- Simple power supply
- Multipurpose use

Description:

The torque transducers series DRBK are suitable for applications in laboratory as well as in industrial environment because of their compact outline and their multiple mounting options. The contactless transmission of supply voltage and measuring signal enables continuous operation with low wear out and no service. For varying applications these transducers are available

also with optional speed detection. The integrated measurement amplifier is supplied with 11,5 to 30 V DC and outputs an analog signal of 0 to ±5V and also a current output of 10 mA ±8 mA. Due to the broad range of supply voltage the transducer can be operated directly at a PLC. This transducer should be used only with the especially designed couplings.

Mechanical Dimensions:

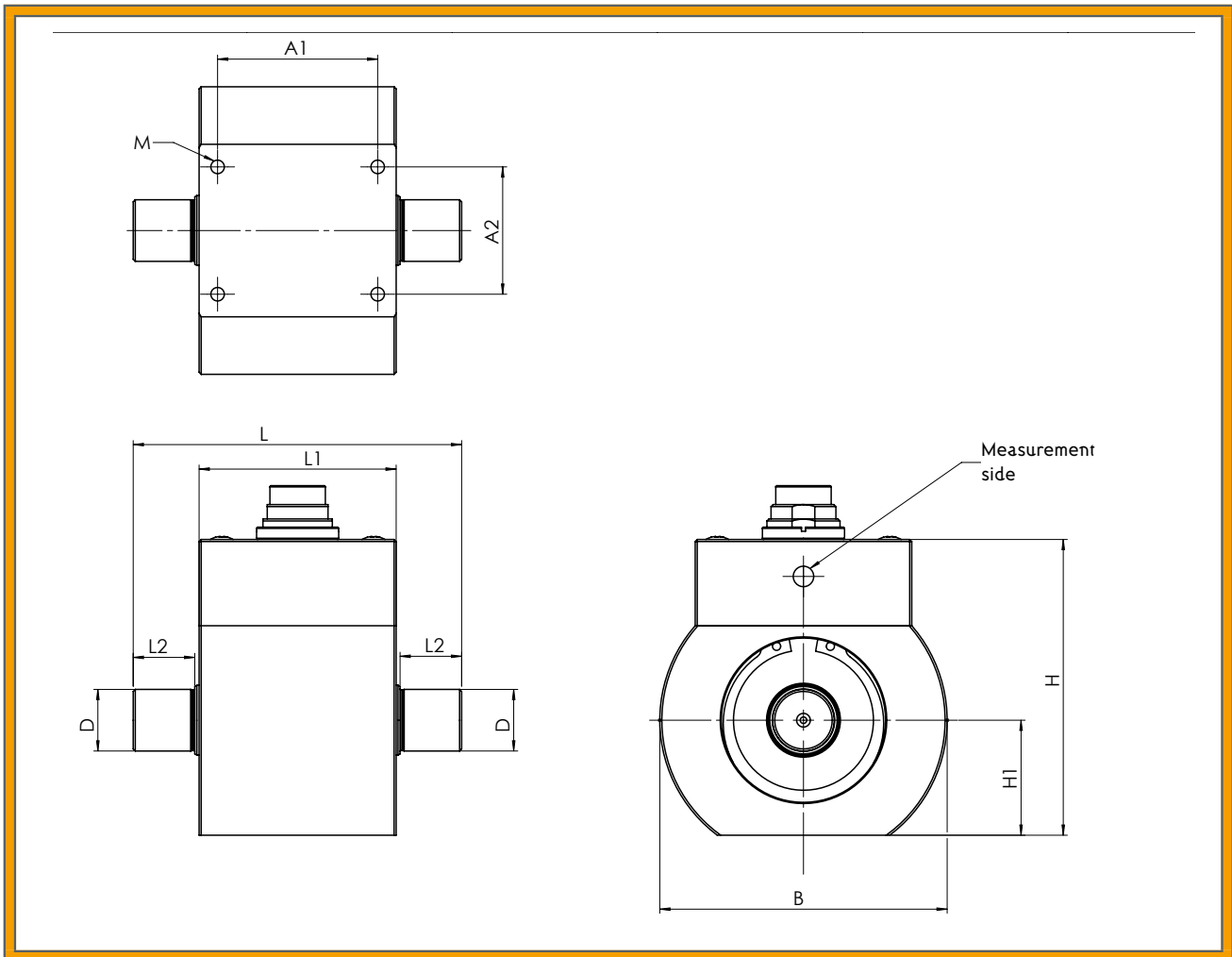

Size	I	II	III
Measurement range: [Nm]	5/10/20	50/100/200	500/1000
Dimensions:			
L [mm]	80	90	120
Ø B [mm]	70	75	105
H [mm]	72	77.5	97.5
H1 ± 0,05 [mm]	28	30	40
Ø D g6 [mm]	15	24	40
L1	48	52	65
L2	15	18	26
A1	39	42	50
A2	31	35	55
M	M4 x 6 tief	M4 x 6 tief	M5 x 10 tief
	General tolerances DIN 2768 - m		
Weight ca.: [g]	550	850	2400
Max. speed [1/min]	22000	16000	9000

Technical Data:

Supply voltage:	11,5 bis 30V DC	Option speed:	(n)
Current consumption:	ca. 200mA	Output:	Open- Kollektor
Rise time 10-90%	1ms	Internal Pull Up:	4,7k Ω (5 V level)
Limit frequency -3dB	1kHz	External Pull Up:	24 V max / 20mA
Voltage output:	0 bis $\pm 5V$	Pulses / rev:	60
Internal resistance:	100 Ω		
Current output:	10 \pm 8mA		
Burden at UB=12V	250 Ω		
Burden at UB=24V	500 Ω		
Ripple:	< 100mVss	Ordering example :	
Nonlinearity:	< 0,3%	DRBK10-n	
Hysteresis:	< 0,3%	Torque transducer measurement range 10 Nm	
Deviation at zero point:	$\leq \pm 100mV / \pm 20\mu A$	Option speed detection	
Max. Measuerment fault:	0,5% (bez. a. d. Endwert)		
Operating temperature:	0-60°C	Available accessories :	
Compensated temperature:	5-45°C	Measurement cable, Couplings, Evaluation device	
Temperature fault:			
Zero point:	0,05%/K		
Sensitivity:	0,02%/K		
Mechanical overload:	100%		
Internal protection:	IP 40 DIN 40050		
Connection:	12pin connector		

The values for axial and radial load refer to the non-fixed housing

Size	Measure- ment range [Nm]	Spring constant C [Nm/rad]	Mass moment of inertia J [g·cm ²]			Maximum axial load [N]	Maximum radial load [N]
			Total	Drive side	Measure- ment side		
I	5	1100	134	116	18	930	25
	10	2700	135	117	18	930	45
	20	5400	136	117	19	930	90
II	50	20 x 10 ³	398	292	106	1580	210
	100	36 x 10 ³	405	296	109	1580	420
	200	52 x 10 ³	424	305	119	1580	845
III	500	290 x 10 ³	3350	1879	1471	3920	1420
	1000	420 x 10 ³	3519	1963	1556	3920	2875

MODEL BKE

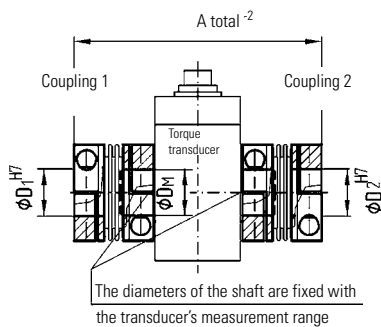
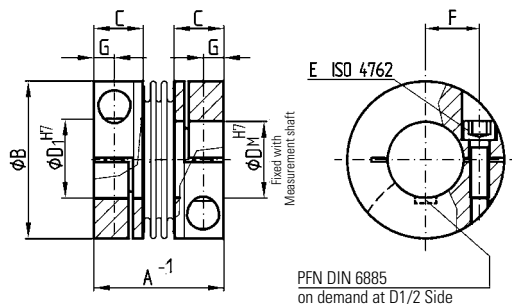

Properties:

- compact design
- easy to mount
- suited for space restricted installations
- low moment of inertia
- economically priced

Material:

Bellows are made of highly flexible high-grade stainless steel, hubs see table

Design:

With a single radial clamping screw per hub ISO 4762

Self opening clamp system optional:
Loosening the clamp screw will force the clamp into open position

Temperature range:

-30 to +100° C

Backlash:

Absolutely backlash-free due to frictional clamped connection

Service life:

These couplings have an infinite life and are maintenance-free if technical limits are not exceeded

Tolerance:

On the hub / shaft connection 0,01 to 0,05 mm

Non-standard:

Custom designs with varied tolerances, keyways, Non-standard material and bellows are available upon request

Model BKE	Series			
		20	200	1000
Rated torque (Nm)	T_{KN}	20	200	1000
Overall length (mm)	A^{-1}	40	59	89
Overall length for installation (mm)	A_{total}^{-2}	130	172	246
Outer diameter (mm)	B	49	66	110
Passungslänge (mm)	C	16,5	23	34
Inner diameter possible from \emptyset to \emptyset H7 (mm)	$D_{1/2}$	15-28	24-35	40-60
Inner diameter for meas. shaft \emptyset H7 (mm)	D_M	15	24	40
Screws ISO 4762		M5	M8	M12
Tightening torque of the fastening screw (Nm)	E	8	40	130
Distance between centers (mm)	F	17	23	39
Distance (mm)	G	6	9,5	13
Mass moment of inertia (10^{-3} kgm ²)	J_{total}	0,05	0,18	7,2
Hub material		AL	AL	Stahl
Approx. weight (kg)		0,13	0,4	3,5
Torsional stiffness (10^3 Nm/rad)	C_T	41,9	138	570
Axial total (mm)		1	1,5	2
Lateral total (mm)	max. Values	0,15	0,15	0,15
Angular total (°)		1	1	1
Axiale spring stiffness (N/mm)	C_a	55,8	153	148
Laterale spring stiffness (N/mm)	C_r	3.710	11.000	9.010
Max. speed (1/min)	n	22.000	16.000	9.000

Ordering example

BKE / 20 / 15 / 22 / XX

Model

Series / Nm

\emptyset DM H7

(fixed with the measurement shaft)

\emptyset D_{1/2} H7

Non-standard

Steel Disc Coupling Type SLR for Transducer DRBK

- backlash-free
- torsion proof
- compact design
- suited for space-restricted installations

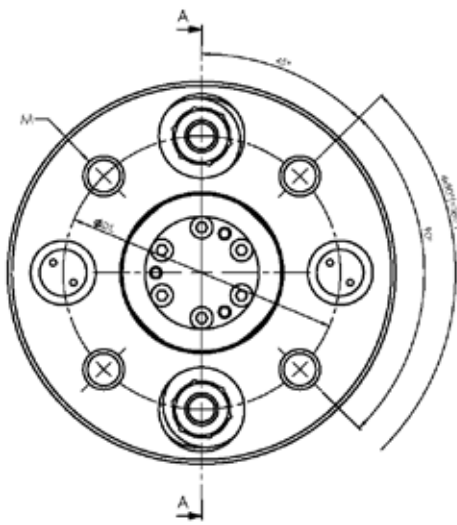
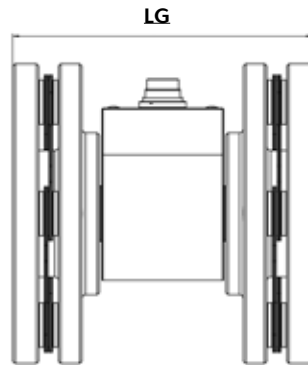

Size 32 und 48

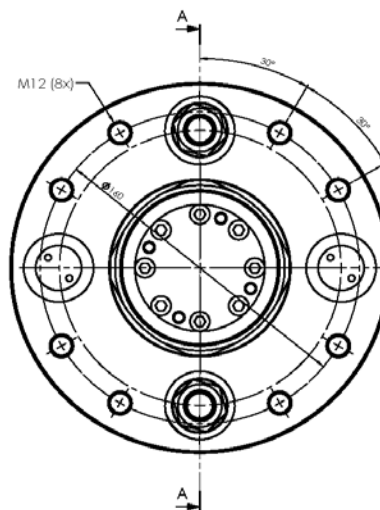

Size 65

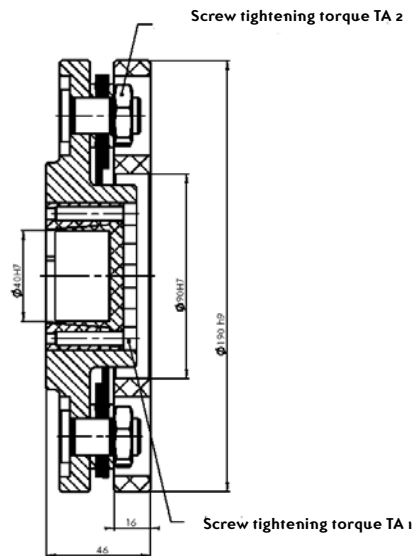

Type	SLR 32	SLR 48	SLR65
max. Torque [Nm]	28	214	1142
Overall length L [mm]	38,5	37	46
length L ₁ [mm]	11	11	16
Overall length with Sensor LG [mm]	127	128	160
Outer diameter D [mm]	95	135	190
Hole circle diameter DL [mm]	68	100	160
Bore diameter d ₁ [mm]	39	65	90
Bore diameter d ₂ [mm]	15	24	40
max. Speed [min ⁻¹]	20.000	14.000	10.000
Screw tightening torque TA ₁ [Nm]	1,9	8,5	18
Screw tightening torque TA ₂ [Nm]	18	20	70
female screw thread M	4xM10	4xM12	8xM12
max. offset of shafts	axial [mm]	1,25	1,75
	angular [degrees]	1	1
Spring clip stiffness [10 ⁶ Nm/rad]	0,15	0,25	0,95
Mass moment of inertia [kgcm ²]	14	50	350
Weight [g]	1600	3700	9500