

# Torque Transducer Type DRB-I for static Application



## Special features:

- insensitive for axial and radial force
- no maintenance needed
- single supply voltage
- for lowest torques suitable
- integrated overload protection

## Description:

This transducer was developed for static, non rotating measurement of torque. Because of its construction the transducer is insensitive of axial and radial force. It supplies a high output signal with low torque values.

## Mechanical dimensions:

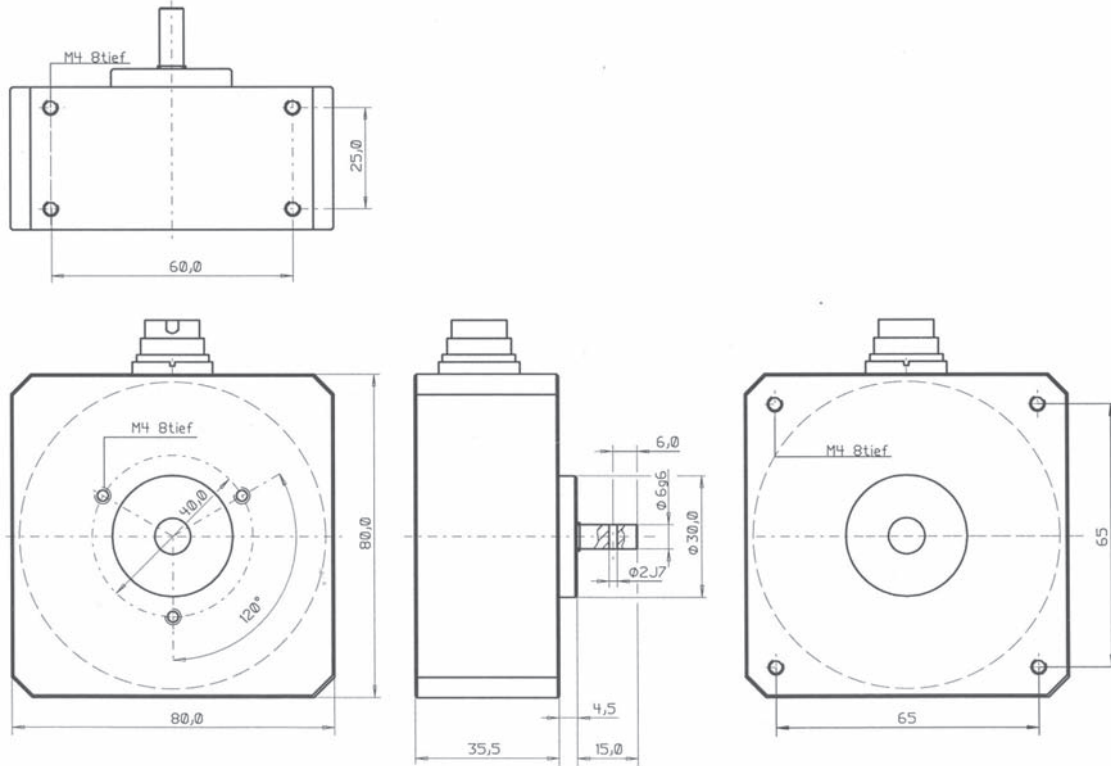

## Technical Data:

Measurement Range:	0,2; 0,5; 1 Nm	Mechanical Overload:	0,2 Nm: 400% 0,5 Nm: 200% 1 Nm: 100%
Supply Voltage:	12 V max.	Thrust Load:	
Current Consumption:	35 mA max.	Axial:	25 N
Voltage Output:	2 mV/V	Radial:	50 N
Nonlinearity:	<0,15 %	Weight:	approx. 600 g
Hysteresis:	<0,1 %	Connection:	6 pin Connector
Internal Resistance:	350 Ω nominal	Protection:	IP 40 DIN 40050
Compensated Temperature Range:	5-45°C		
Operating Temperature:	0-60°C		
Temperature fault			
Zero Point:	0,02 % / K		
Sensitivity:	0,01 % / K		

### Ordering Example: DRB-I-0,2

Torque transducer measuring range 0,2 Nm

Available Accessories: Connectors, measuring cable, supply and display unit